

User Manual

Z BOX-I ALL-IN-ONE ESS Cabinet

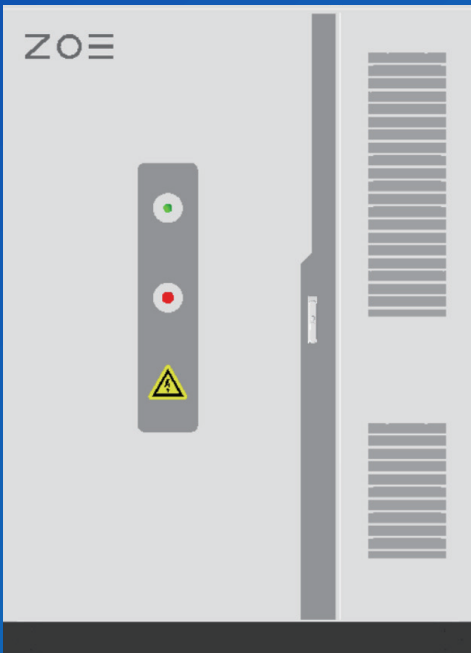

I 156-1H

150kW / 156kWh | 1C

Please carefully read the energy storage system user manual before use.

Read and retain these instructions.

Copyright © Fuzhou ZOE Energy Storage Technology Co., Ltd. (referred to as ZOE hereafter) 2023. All rights reserved.

Without the authorization of our company, no unit or individual may excerpt or copy any part or all of the contents of this document, and may not distribute it in any form.

All other trademarks or registered trademarks mentioned in this document are the property of their respective owners.

Without prior written consent from ZOE or the trademark or trade name owner, this manual does not grant readers permission or rights to use any marks appearing in this manual in any way.

This product meets the design requirements for environmental protection and personal safety. Storage, use, and disposal of the product should comply with the requirements of the product manual, relevant contracts, or relevant laws and regulations.

When there are product updates or technical changes, you can inquire about relevant information through the ZOE website. If this product is improved or technologically changed, no separate notice will be given.

Trademark Statement



and other ZOE trademarks are trademarks of Fuzhou ZOE Energy Storage Technology Co., Ltd.

All other trademarks or registered trademarks mentioned in this document are the property of their respective owners.



Catalog

PREFACE	5
OVERVIEW	5
ATTENTION	5
AUDIENCE	5
MANUAL USAGE	5
SYMBOL USAGE	5
1 SAFETY PRECAUTIONS	6
1.1 PERSONNEL REQUIREMENTS	6
1.2 ELECTRICAL SAFETY	6
1.3 BATTERY SAFETY	7
1.4 LIFTING AND TRANSPORTATION	8
1.5 INSTALLING AND WIRING	8
1.6 OPERATION AND MAINTENANCE	8
1.7 PRODUCT DISPOSAL	9
2 PRODUCT DESCRIPTION	10
2.1 PRODUCT MODEL DESCRIPTION	10
2.2 PRODUCT OVERVIEW	10
2.3 APPEARANCE DESIGN	13
2.4 INTERNAL DESIGN	16
2.5 ELECTRICAL PRINCIPLES	22
2.6 TEMPERATURE CHARACTERISTICS	22
2.7 DATA DETECTION	22
2.8 CIRCUIT PROTECTION	23
2.9 SAFETY PROTECTION	23

2.10 PRODUCT APPLICATION 23

2.11 SYSTEM COMMUNICATION 23

2.12 TRANSPORTATION AND STORAGE 23

3 INSTALLATION 24

3.1 INSTALLATION PRINCIPLES 24

3.2 INSTALLATION PREPARATION 24

3.3 FOUNDATION REQUIREMENTS 25

3.4 INSTALLATION PREPARATION 25

4 POWER ON AND OFF 31

4.1 PRE-POWER-ON CHECK 31

4.2 POWER-ON STEPS 32

4.3 POWER OFF AND SHUTDOWN 32

5 EQUIPMENT OPERATION CONTROL 33

5.1 LOGIN 33

5.2 SYSTEM MAIN INTERFACE 33

6 WARRANTY DESCRIPTION 34

7 NOTE 35

8 APPENDIX 36

8.1 COMMON FAULT INFORMATION AND PARTIAL HANDLING MEASURES 36

8.2 CONTACT INFORMATION 37

Preface

Overview

This document mainly introduces the methods of installation, electrical connection, commissioning, and troubleshooting of the Z BOX-I01 energy storage system (referred to as the BESS hereafter). Please read this manual carefully before installing and using the energy storage system, understand the safety information, and familiarize yourself with the functions and characteristics of the energy storage system.

Attention

Before installing, operating, or maintaining this equipment, please read this manual carefully and familiarize yourself with this equipment.

Audience

This manual is applicable to power station operators and electrical technicians with corresponding qualifications.

Manual Usage

Before using the product, please read the manual carefully. The content of the manual will be continuously updated and corrected, but there may be slight discrepancies or errors compared to the actual product. Users should refer to the physical product they purchased and can obtain the latest version of the manual materials through the company's official website or sales channels.

Symbol Usage

To ensure the personal and property safety of users when using the product, relevant information is provided, and the following symbols are used to emphasize it. The following symbols that may be used in this manual are listed. Please read them carefully to better use this manual.

 **Danger** Indicates a potential hazard. Failure to follow instructions may result in serious personal injury or death.

 **Warning** Indicates a potential hazard. Failure to follow instructions may result in serious personal injury or equipment damage.

 **Caution** Indicates a potential hazard. Failure to follow instructions may result in serious equipment damage.

 **Note** Used to convey equipment or environmental safety warning information. Failure to follow instructions may result in equipment damage, data loss, decreased equipment performance, or other unpredictable results, not involving personal injury.

1 Safety Precautions

1.1 Personnel Requirements

The lifting, transportation, installation, wiring, operation, and maintenance of the BESS must be carried out by professional electrical technicians who comply with local regulations. Operators must meet the following requirements:

- Should possess certain knowledge of electronics, electrical wiring, and mechanics, and be familiar with electrical and mechanical schematics.
- Should be familiar with the composition and working principles of the BESS; familiar with the composition and working principles of the BESS and its front and back-end equipment.
- Should have received professional training related to the installation and commissioning of electrical equipment.
- Should have the ability to respond to emergencies or unforeseen situations that may arise during installation or commissioning.
- Should be familiar with the relevant standards and regulations of the country/region where the project is located.

1.2 Electrical Safety

Danger

- There is a risk of electric shock when touching points, terminals, etc., connected to the power grid or the internal equipment!
- Both the battery side and the grid side may produce voltage. Before touching, always use a standard voltmeter to confirm that there is no voltage.

Danger

There is a lethal high voltage inside the product!

- Pay attention to and comply with the warning signs on the product.
- Follow the safety precautions listed in this manual and other relevant documents of the equipment.
- Follow the protective requirements and precautions of the battery.

Danger

- When disconnecting the power supply of the BESS, the battery will not immediately power off.
- Wait for 10 minutes to ensure that the equipment is completely de-energized before proceeding with operations.

Warning

- All lifting and transportation, installation and wiring, operation and maintenance must comply with the relevant regulations and ordinances in the project area.
- It is essential to use the BESS as required by this manual. Otherwise, equipment damage may occur.

Caution

To prevent unauthorized personnel from approaching the energy storage container and causing accidents or mishandling, please adhere to the following precautions:

- Place prominent warning signs around the BESS to prevent accidental closures that could lead to accidents.
- Erect warning signs or set up safety tapes near the equipment.

1.3 Battery Safety

To safely use the product, technical personnel should carefully read and comply with the following safety requirements. Product malfunctions, component damage, personal safety accidents, property losses, etc., caused by the following reasons are not within the company's responsibility:

- Battery capacity loss or irreversible damage caused by customer's failure to charge the battery in time;
- Battery damage, drops, leaks, etc., caused by improper operation or failure to operate the battery as required;
- Battery damage caused by customer's failure to power up in time resulting in over-discharge of the battery;
- Battery damage caused by improper equipment used for charging and discharging by the customer;
- Battery frequent over-discharge due to improper maintenance by the customer, on-site capacity expansion, or inability to fully charge for a long time;
- Battery damage caused by customer's failure to correctly set battery operating parameters;
- Direct damage to the battery caused by the on-site operating environment not meeting the requirements for normal operation;
- Customer-initiated changes to battery usage scenarios, including but not limited to: connecting additional loads to the battery by themselves;
- Failure to correctly maintain the battery according to the system manual provided by the matching equipment;

- Product damage caused by continued use of batteries beyond the warranty period by the customer;
- Product damage caused by using defective or deformed batteries;
- Mixing batteries provided by the company with other batteries, including but not limited to: mixing with batteries of other brands, mixing with batteries of different rated capacities, etc.;
- Product damage or other property losses caused by storing or installing batteries together with flammable/explosive materials;
- Personal safety accidents, property losses, etc., caused by failure to wear standard protective equipment during battery-related operations, which should be performed by professional personnel;
- Battery damage caused by eating, drinking, smoking, etc., near the battery;
- Theft of the battery.

1.4 Lifting and Transportation

Warning

- If walking on top of the equipment is necessary, please follow the procedures for working at heights.

1.5 Installing and Wiring

Warning

Throughout the entire process of mechanical installation, strict compliance with the relevant standards and requirements of the project location is required.

Warning

Only equipment designated by ZOE should be used. Failure to use designated ZOE equipment may result in compromised protection functions and personal injury.

1.6 Operation and Maintenance

Warning

- Personal protective equipment must be worn when performing maintenance, inspections, and other work on the energy storage system.
- Maintenance personnel must wear safety goggles, helmets, insulated shoes, gloves, etc.

 **Warning**

- There are no user-serviceable parts inside the battery unit.
- Users are not permitted to maintain the battery themselves. Only personnel approved by ZOE may remove, replace, or handle the battery.

 **Warning**

- To reduce the risk of electric shock, do not perform any maintenance operations beyond those specified in this manual.
- If necessary, contact ZOE customer service personnel for repairs.

 **Warning**

- To ensure continuous fire protection, internal components should only be replaced by professional personnel.

 **Danger**

- Disassembling or incinerating the battery may cause it to catch fire.

 **Caution**

- No components inside or outside the equipment should be sprayed with any substance.
- Do not use cleaning agents to clean the equipment or expose it to irritating chemicals.

1.7 Product Disposal

When the entire BESS or individual internal devices need to be discarded, they should not be disposed of as regular waste. Some components inside the internal machinery can be recycled for reuse, while others may cause environmental pollution. Please contact authorized local professional recycling organizations for proper disposal of the product and internal components.

2 Product Description

2.1 Product Model Description

This document primarily concerns the following product models:

I01-90KN-94 I01-100KN-104 I01-110KN-114
I01-120KN-125 I01-120KN-135 I01-150KN-156

For example, the I01-150KN-156 is as follows:

I 01-150K N-156

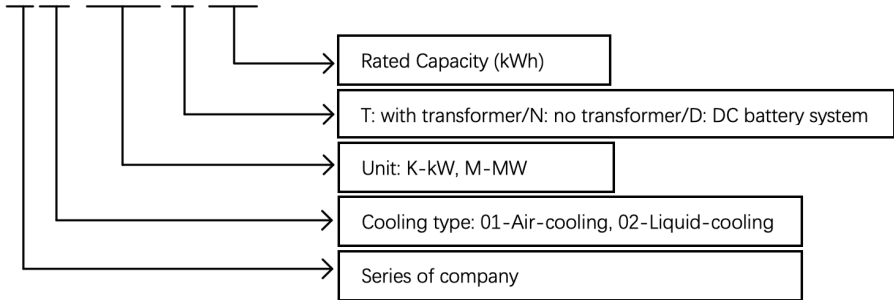

2.2 Product Overview

The I01-150KN-156 series energy storage outdoor cabinet is an all-in-one BESS. Built around a power platform ranging from 90kW to 150kW, it is configured with a battery capacity of 94kWh to 156kWh. With flexible and reliable configuration, high safety, it is suitable for various scenarios such as industrial parks, large farms, microgrids, where grid quality is unstable and grid frequency regulation is required. It integrates EMS, HVAC, and fire protection to ensure system safety and power stability.

2.2.1 Technical Parameters

Product Model	I01-90KN-94	I01-100KN-104	I01-110KN-114	I01-120KN-125	I01-120KN-135	I01-150KN-156
AC SIDE						
Rated Output Power (kW)	90	100	110	120	120	150
PCS config	2*60kW (PCS+DC/DC)	2*60kW (PCS+DC/DC)	2*60kW (PCS+DC/DC)	2*60kW (PCS+DC/DC)	2*60kW (PCS+DC/DC)	3*50kW (PCS)
Rated Grid Voltage (V)	400					
Voltage range	-20% ~ +15%					
Grid Frequency (HZ)	50/60					
AC Wiring Type	3P4L + PE					
Rated Output Current (A)	129	144	158	173	173	216
Power Factor	0.8cap ~ 0.8ind					
THDi	≤ 3% (Full Load)					
Charge/ Discharge Switch time (ms)	< 100					
DC SIDE						
Rated Capacity (Ah)	102					
Serial/ Parallel	2P16S*9	2P16S*10	2P16S*11	2P16S*12	2P16S*13	2P16S*15
Rated Voltage (V)	460	512	563	614	665	768
Voltage Range (V)	403~518	448~576	492~633	537~691	582~748	672~864
Rated Capacity (kWh)	94	104	114	125	135	156
Rated C Rating	≤1C					
Protection						
Over Voltage	Equipped					
Over Current	Equipped					
Short Circuit	Equipped					
Over Temp	Equipped					
Basic Info						
Efficiency	> 89%					
Operating Tempe (°C)	-30 ~ 55					
Relative Humidity	0-95% (Non-Condense)					
Noise (dB)	< 75					
Dimension (W*H*D mm)	1500*2200*1300					
Weight (T)	< 2.8					
IP Level	IP54					
Cooling Type	Intelligent Air-Cooling					
Fire Suppression	Perfluorohexanone + Aerosol					
Max. Altitude (m)	≤2000					
COM Interface	WiFi+4G+LAN					
Display	Local Touch Screen					

2.2.2 Product Advantages

(1) Intelligent and Efficient

- Intelligent temperature control system, efficient heat management, extending battery life
- 1C rapid response, supporting various modes such as virtual power plants, grid connection, off-grid, etc.
- Cloud collaboration, remote intelligent monitoring, online upgrades, full lifecycle management

(2) Safe and Reliable

- Comprehensive data monitoring with multiple sampling points to ensure system safety
- Mature battery balancing technology
- AI monitoring and warning functions

(3) Highly Integrated

- Modular design, supporting parallel networking of multiple sets of equipment
- All-in-one integration technology, separate temperature zoning management of AC and DC compartments
- Compact structure, exquisite appearance, flexible configuration, wide power range

(4) Convenient and Economical

- Simple construction, suitable for various application scenarios
- Over 10 years of service life under standard conditions
- Flexible combination and selection of multiple energy levels

2.2.3 Application Fields

Microgrid systems, commercial buildings, distributed industrial and commercial parks, remote villages, border outposts, island off-grid, microgrids, etc.

2.3 Appearance Design

2.3.1 Cabinet Appearance

The appearance structure of the BESS is as shown in the figures below.

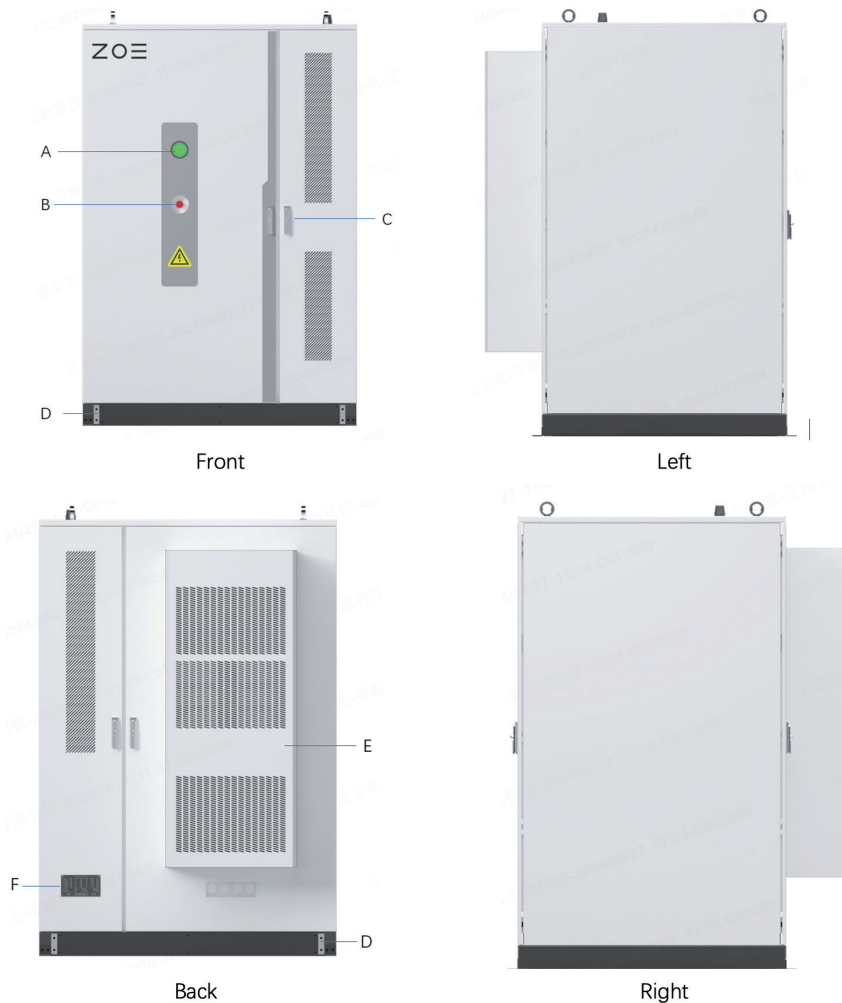

*The figures are for reference, please refer to actual product.





Number	Item
A	LED Indicating Light
B	Emergency Stop
C	Door Lock
D	Grounding Point
E	Air Conditioning
F	Nameplate

⚠ Caution

- The nameplate contains important parameter information related to the ESS, which should be protected during transportation, installation, maintenance, inspections, and other operations. Destruction or removal is strictly prohibited!

LED

LED indicators are located directly on the BESS cabinet, displaying color status as follows:

Status	Description
	System is operating normally (charging/discharging)
	System is in normal standby mode, not charging or discharging
	System has encountered a fault (auxiliary power not disconnected)
	Auxiliary power is disconnected

Emergency Stop Button: In case of emergency, pressing this button will halt the system.

⚠ Danger

- Pressing the emergency stop button halts the system, disconnecting both AC and DC breakers. However, internal auxiliary power and PCB boards remain live, please do not touch.

2.3.2 Mechanical Parameters

Dimensions: The external dimensions of the BESS cabinet are as shown in the figures below.

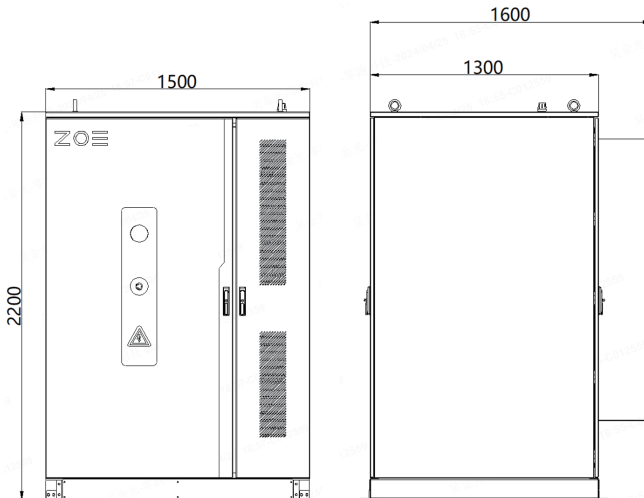

Fig 2.2-1 Dimensions of the BESS

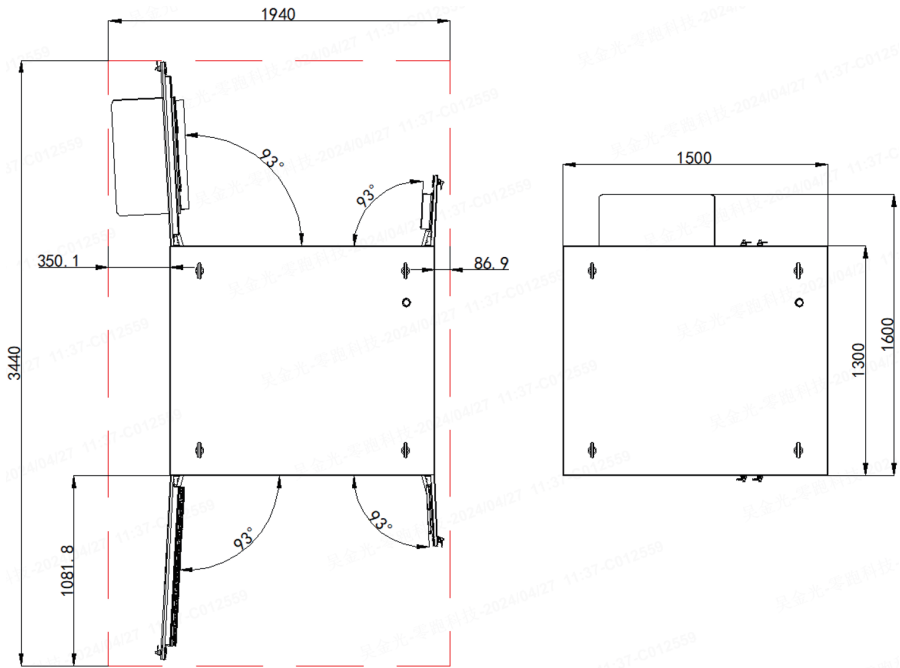
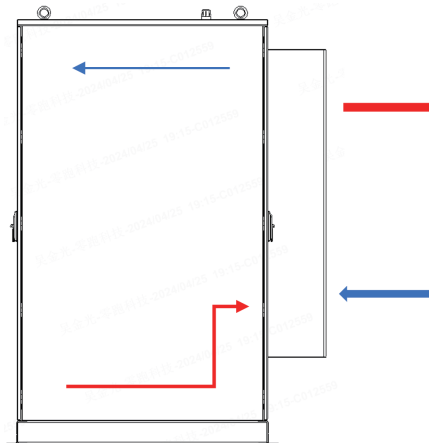

Fig 2.2-2 Max door opening dimensions

2.3.3 Ventilation Design

The BESS cabinet employs internal and external circulation ventilation design. Cold air is emitted from the top air outlet of the air conditioner inside the cabinet and warm air is recirculated from the bottom air inlet. Externally, cold air is absorbed from the bottom and hot air is emitted from the top for heat dissipation, as depicted in the figure below.



2.4 Internal Design

2.4.1 Internal Equipment Layout

The main electrical equipment inside the BESS cabinet is illustrated in the diagram below:

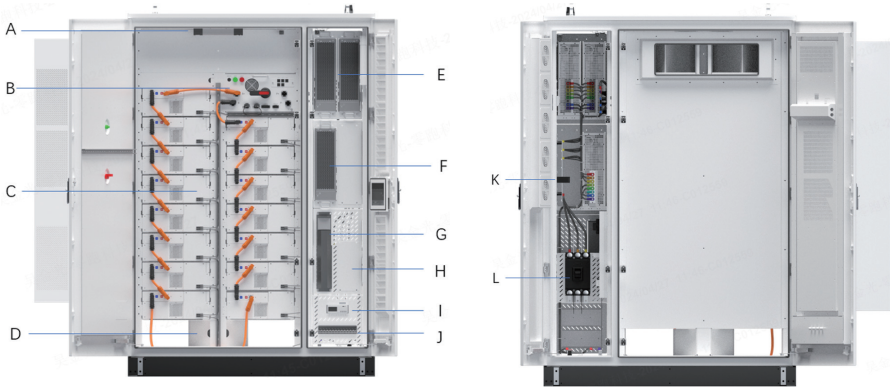

Number	Item
A	Light
B	High Voltage Box
C	Battery Cluster
D	Fire Suppression System
E	PCS/DCDC
F	PCS
G	UPS
H	EMU
I	Electric Meter
J	Distribution Switch
K	Current Transformer
L	AC Molded Case Circuit Breaker

*The above illustration is for reference only. Please refer to the actual item received for accuracy.

2.4.2 Power Conversion System (PCS)

Appearance

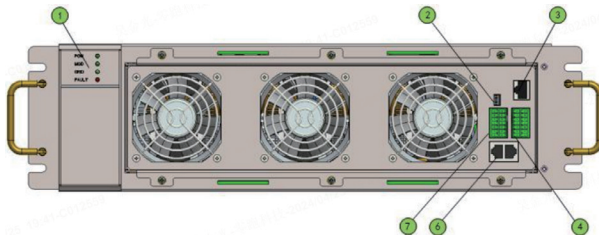

Front Panel (Dust Cover removed)

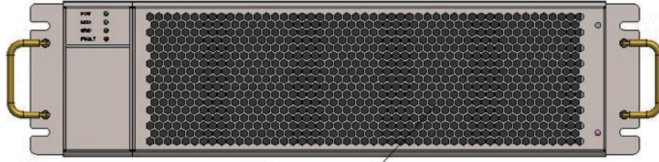

5
Front Panel

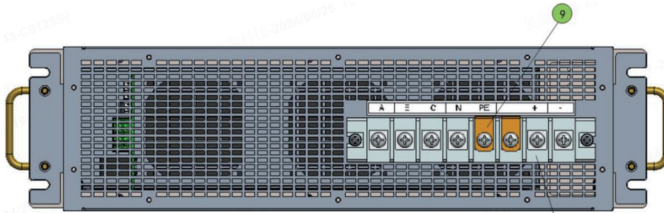

8
Rear Panel

Number	Item
1	LED Indicating Light
2	Communication matching resistor DIP switch (master DIP switch is set to 1, slave is set to 0)
3	RJ45 Interface
4	BMS & other Communication Interfaces
5	Dust Cover
6	Communication Interface for parallel operation
7	Module Communication & DI/DO Interface
8	Input & Output Terminal
9	PE Short-circuit Metal Piece

LED Indicator Panel: The LED indicator panel serves as a human-machine interface, indicating the current operating status of the PCS.

POW	●
MOD	●
GRID	●
FAULT	●

Indicating Light	Indicating Light Description	
	Indicating Light Status	Status Description
POW		On Standby
		Flash Powering ON
MOD		On Standby
		Flash Charging
		Rapid Flash Discharging
GRID		On Off Grid
		Flash Grid Connect
FAULT		On Fault
		Off No Fault

2.4.3 DC/DC

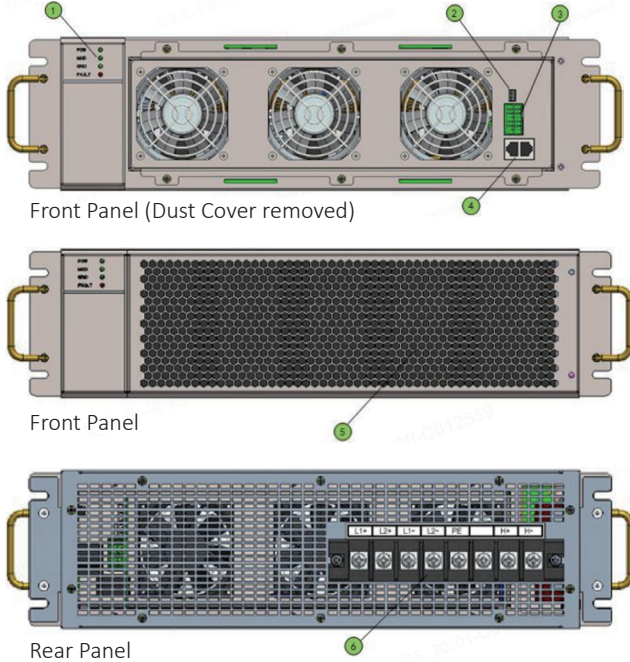

Number	Item
1	LED Indicating Light
2	Communication matching resistor DIP switch
3	Module Communication & DI/DO Interface
4	Communication Interface for parallel operation
5	Dust Cover
6	Input & Output Terminal

LED Indicator Panel: The LED indicator panel serves as a human-machine interface, indicating the current operating status of the DC/DC.

Indicating Light	Indicating Light Description	
	Indicating Light Status	Status Description
POW		On Standby
		Flash Powering ON
MOD		On Standby
		Flash Charging
		Rapid Flash Discharging
GRID		∟ ∟
		∟ ∟
FAULT		On Fault
		Off No Fault

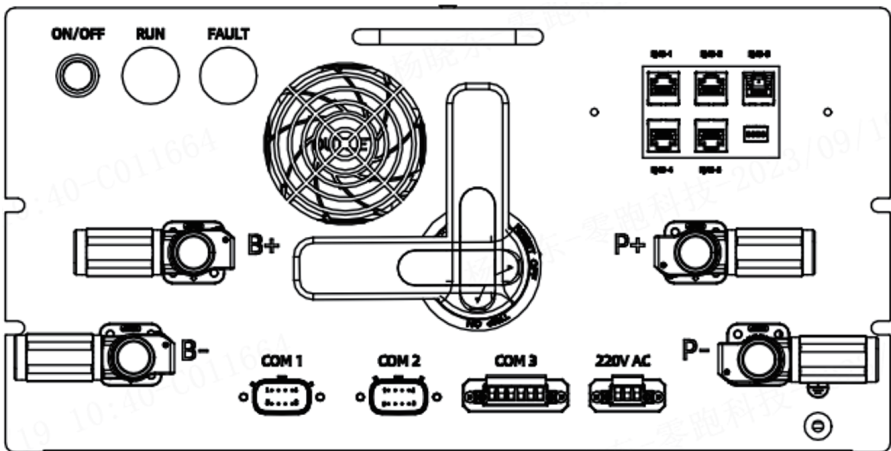
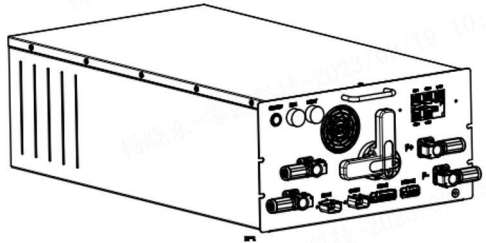
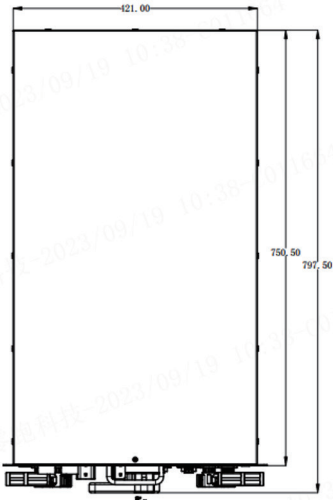
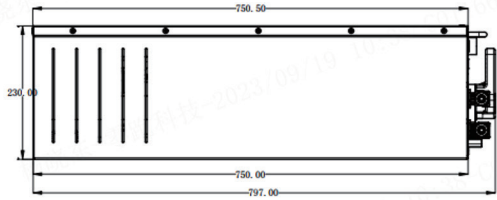
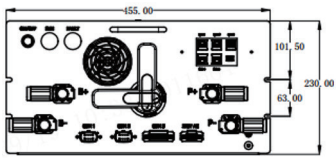

2.4.4 High Voltage Box (HVB)

High Voltage Box: Distribution box Appearance of operation panel of distribution box is as shown in the figure below.



Number	Port Identification	Port Definition	Description
1	ON/OFF	HVB Power Button	HVB Power
2	RUN	System Running Status Indication Light	Constant Green: System Normal Operation
3	FAULT	System Fault Indication Light	Constant Red: System fault
4	B+	Battery Positive	Battery Positive Input
5	B-	Battery Negative	Battery Negative Input
6	COM1	COM1 Port	Debugging, Loopback, 12V input
7	COM2	COM2 Port	Communication & Control of Battery
8	COM3	COM3 Port	Signal Control of Dry Contact
9	220V AC	AC Power Supply Interface	220V AC Input
10	P+	HVB Positive	Positive of HVB, connect to PCS
11	P-	HVB Negative	Negative of HVB, connect to PCS
12	RJ45 1/ RJ45 2	CAN Interface	Communication to PCS
13	RJ45 4/ RJ45 5	RS485 Interface	Communication to EMS
14	RJ45 3	Reserved Interface	Reserved Interface
15	DIP Switch	BCMU Address Allocation	DIP Address Allocation, default is 1

Indicator light

Indicator Light	Colour	Display Status	Status Description	Remarks
ON/OFF (Low Voltage Power)		Constant On	ON/OFF Low Voltage Button is Closed	Power Light is constant on
		Off	ON/OFF Low Voltage Button is Open	Power Light is off
RUN		Off	The handle switch is not closed, and the main relay of high voltage is disconnected	Green Light is off
		Flash	The handle switch is closed, the main relay of high voltage is closed, and the high voltage bus current is $\leq 1A$	Green Light flashes
		Constant On	The handle switch is closed, the main relay of high voltage is closed, and the high voltage bus current is $> 1A$	Green Light is constant on
FAULT		Off	The battery system is running normally without faults or the battery system has a level 1 warning	Red Light is off
		Flash 1 (On 0.5s, Off 0.5s)	The battery system has a level 2 system fault alarm	Red Light flashed
		Flash 2 (On 1.5s, Off 0.5s)	The battery system has a level 3 system fault alarm	Red Light flashes
		Constant On	The battery system has a serious fault protection	Red Light is constant on

DIP switch default address status

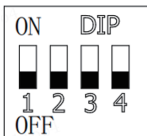

Encoding Address		DIP switch position			
Decimal	Hexadecimal	1	2	3	4
0	0	OFF	OFF	OFF	OFF
1	1	ON	OFF	OFF	OFF

2.4.5 Battery

Battery Cell

Table 2.4-1 Battery cell parameter

Battery Cell	Parameter	Value
	Dimension (D*H*W)	(50.1±0.5)mm* (118.5±0.5)mm*(160.0±0.8)mm
	Weight	1985±100g
	Rated Capacity (Ah)	102Ah
	Rated Capacity (Wh)	320Wh
	Rated Voltage	3.2V
	Voltage Range	2.5 V~ 3.65 V (Battery Cell T>0°C) 2.0 V~ 3.65 V (Battery Cell T≤0°C)

Battery Pack

The battery pack (PACK) is mainly composed of battery cells in series, and has functions such as battery voltage and temperature collection and balance control. It adopts a dedicated battery management chip design, receives control commands through the daisy chain communication method, and reports collected data.

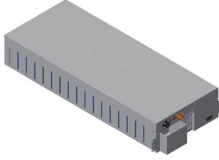
Battery Pack	Parameter	Value
	Model	I01-P10-3A
	Dimensions (L*W*H)	(1040±5) × (466±5) × (165±5) mm
	C rating	≤1C
	Battery Cell type	Square aluminium shell LFP
	Serial-Parallel type	2P16S
	Key components	32 battery cells, 1 BSU
	Weight	85±5kg
	IP level	IP20

2.4.6 Fire Suppression System

An integrated 3KG perfluorohexane extinguishing device is used to protect the battery box. After the composite probe detects the fire signal, the extinguishing device is activated and delivered through the pipeline to the thermal uncontrolled battery compartment; an aerosol is used for fire extinguishing in the electrical compartment.

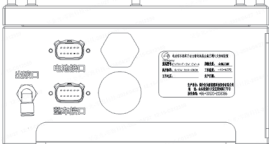
Battery Pack	Parameter	Value
	Perfluorohexane extinguishing device	3kg, including fire suppression control device
	Composite detection controller	Integrated temperature, smoke, CO gas, and electrolyte volatile gas detection sensors, equipped with 1 set in the battery compartment and electrical compartment each
	QRR0.3G/S-Q Aerosol fire extinguishing device	Electrical compartment fire extinguishing, protection space 3m ³
	Board-penetrating nozzles and pipes	Three nozzles in upper, middle, and lower positions

2.5 Electrical Principles

Model I01-150

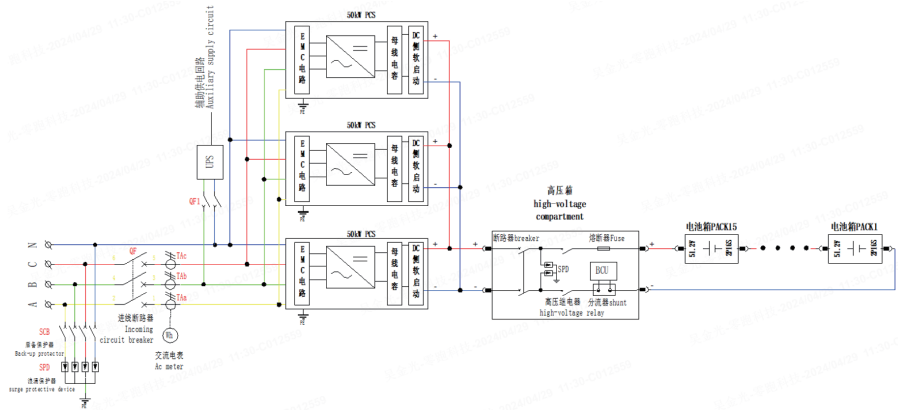

Model I01-90 ~ 120

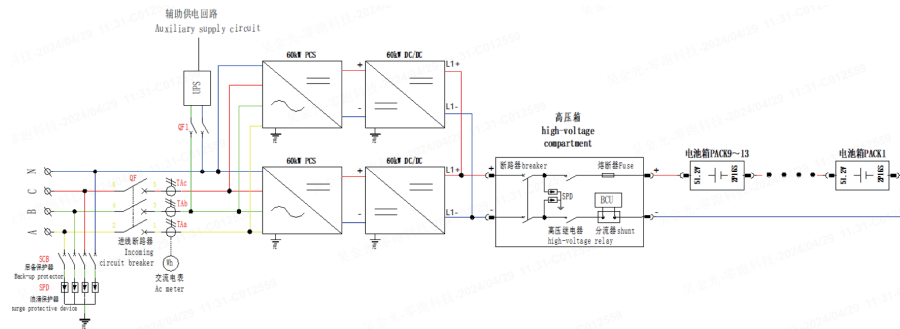

2.6 Temperature Characteristics

Operating environment temperature: $-30^{\circ}\text{C} \sim 55^{\circ}\text{C}$

Safety storage environment temperature: $-20^{\circ}\text{C} \sim 60^{\circ}\text{C}$

Recommended storage environment temperature: $25 \pm 5^{\circ}\text{C}$

Recommended operating environment temperature: $0^{\circ}\text{C} \sim 40^{\circ}\text{C}$

2.7 Data Detection

The battery system can detect the battery operating status (voltage, current, temperature, SOC/SOH/SOP estimation, etc.) and adjust the battery charging and discharging and energy storage according to the current status of the battery and the actual performance of the

electrical components.

2.8 Circuit Protection

The battery system is equipped with high-voltage sampling and circuit breakers, fuses, and other safety devices that provide status feedback functions. When a fault occurs in the battery, the system will report and limit the charging and discharging current or power, delay the disconnection of the contactor, and protect the safety of the power system.

2.9 Safety Protection

The energy storage cabinet is equipped with smoke, temperature, combustible gas, water immersion, and other multi-functional detectors, as well as a perfluorohexane fire extinguishing system. It can detect potential safety hazards in the cabinet in real-time and prevent fire accidents such as accidental battery fire and other fire safety accidents.

2.10 Product Application

As an independent system accessing the grid, it sends power instructions to the PCS host through the frequency control controller. The PCS host automatically allocates power to the slave machines for operation according to the required set values. The energy storage PCS dynamically adjusts the charging and discharging parameters based on the power setting data of the scheduling platform, and performs corresponding charging and discharging functions to regulate the grid frequency.

2.11 System Communication

The system has an embedded EMS system, which comprehensively manages and maintains the entire machine's BMS, PCS, environmental monitoring, fire protection, air conditioning, and safety monitoring equipment. It has developed protocols to quickly integrate with third-party EMS or power plant operation systems, reducing equipment deployment and maintenance costs, and introducing a new generation of industrial-grade station control servers.

2.12 Transportation and Storage

(1) Transportation

Suitable for trucks, ships; during transportation, it should be covered, sun-shaded, handled gently, and loading and unloading are allowed on any means of transportation. During loading and unloading, the battery should be handled carefully to prevent throwing, rolling,

and heavy pressure, and horizontal placement is prohibited. During transportation, direct exposure to rain, snow, and mechanical impact should be avoided.

(2) Storage

When storing the BESS, it should be placed in a dry warehouse and not exposed to sunlight or rain. Harmful gases, flammable and explosive products, and corrosive chemicals are not allowed in the warehouse. Mechanical impacts, heavy pressure, and strong magnetic field effects should be avoided. It should not be exposed to direct sunlight, and the distance from the heat source should not be less than 2m. The packaging box should be at least 20cm above the ground and at least 50cm away from walls, windows, or air inlets. Under these conditions, the product should be charged to 50% SOC within 6 months after leaving the factory, and capacity verification tests and re-inspections should be conducted every 12 months.

3 Installation

3.1 Installation Principles

The BESS is a high-voltage energy storage device and is classified as a dangerous good. Improper operation and usage by non-professionals may cause serious consequences such as electric shock, combustion, explosion, etc. The installation and maintenance of the battery system must be carried out by professional technicians or trained designated personnel, and relevant safety regulations must be strictly followed during use.

3.2 Installation Preparation

The energy storage system is an integrated unit, and it should not be disassembled during transportation or installation. Faults caused by unauthorized modifications are not covered by the warranty.

Caution

- Installation should not be conducted in adverse weather conditions such as rain or dust storms.
- Foreign objects should not be inserted into any part of the energy storage cabinet.
- The BESS or its components should not be directly exposed to flames.
- The BESS should not be installed near heating equipment.
- The BESS or its components should not be immersed in water or other liquids.
- The BESS should be placed on a level surface to ensure stable placement without shaking or tilting.
- Cleaning agents should not be used to clean the BESS, and the BESS should not be exposed to flammable or irritating chemicals or vapours.

Warning

- When installing, operating, and maintaining, it is strictly prohibited to wear watches, bracelets, or other conductive objects to avoid electric shock.
- When installing the energy storage cabinet, do not attempt to open, dismantle, repair, tamper with, or modify the energy storage cabinet.
- Do not use parts or accessories not authorized by ZOE.
- Specific tools and equipment used in actual operations shall prevail.
- The installation of the battery system should consider the bearing and load capacity of the installation ground and floor.

3.3 Foundation Requirements

a) Unless otherwise specified, the concrete grade is C30, the floor thickness is 200mm, each side protrudes 300mm from the edge, and it is equipped with third-grade steel to meet the double-layer bidirectional.

b) Reinforcement uses HRB400 grade (third-grade steel symbol), and after rust removal, it should be treated with anti-corrosion treatment according to relevant specifications.

c) The thickness of the floor mat is 100mm, and the concrete strength is C15.

d) The bearing layer of the foundation should be in-situ soil, and the characteristic value of the bearing capacity should not be less than 100KPa. If the bearing layer of the foundation is soft soil, sand and gravel should be used for replacement, and the depth of replacement should not be less than 500mm. The replacement soil layer must be layered, compacted, and the compacted layer thickness should not be greater than 300mm, with a compaction coefficient greater than 0.94. The replacement layer should extend beyond the foundation edge by 300mm, and the bearing capacity characteristic value after replacement should not be less than 100KPa. During replacement, the particle size of particles smaller than 0.75mm should not exceed 10%.

e) Measures should be taken to reduce water during foundation construction, and it is strictly forbidden for the foundation pit to be waterlogged. Safety and reliable support measures should be taken for excavation of foundation pits.

f) Ground levelling requirements: within 2m, the deviation of flatness should be less than ± 4 mm.

3.4 Installation Preparation

(1) Prepare Common Tools

(2) Unpacking

(3) Inspection and Verification

- Appearance: uniform colour, clear markings, complete and correct printing.
- BESS cabinet: includes batteries, high-voltage boxes, AC distribution components.
- All power cables and communication cables inside the cabinet.
- One user manual.

(4) Installation Steps

Lifting Illustration

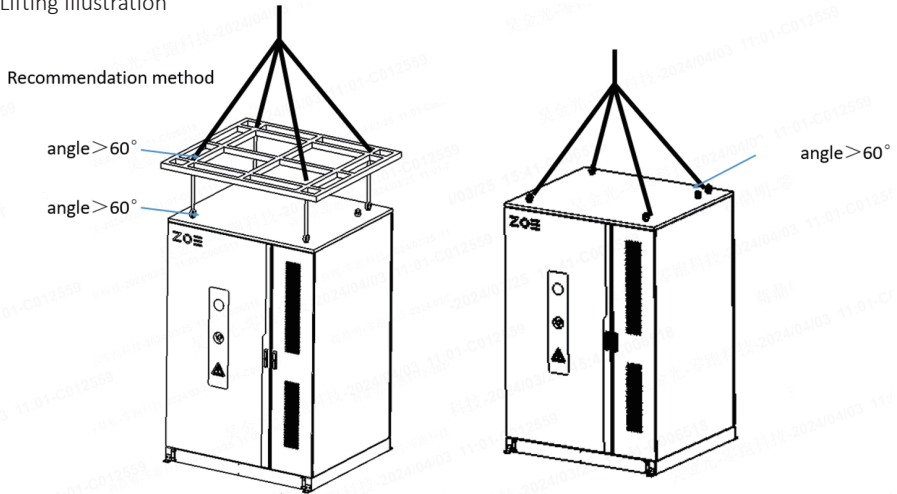

Forklift Illustration

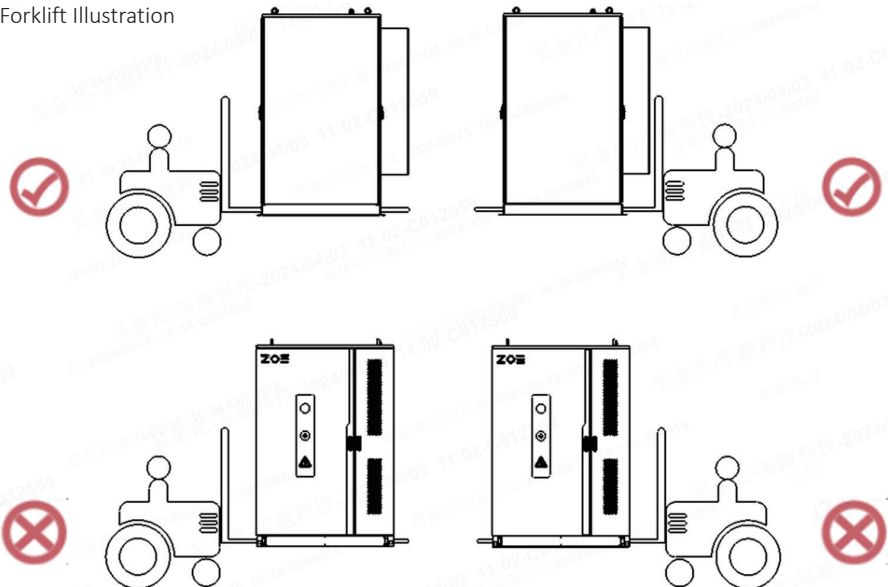

Bottom Fixing Illustration

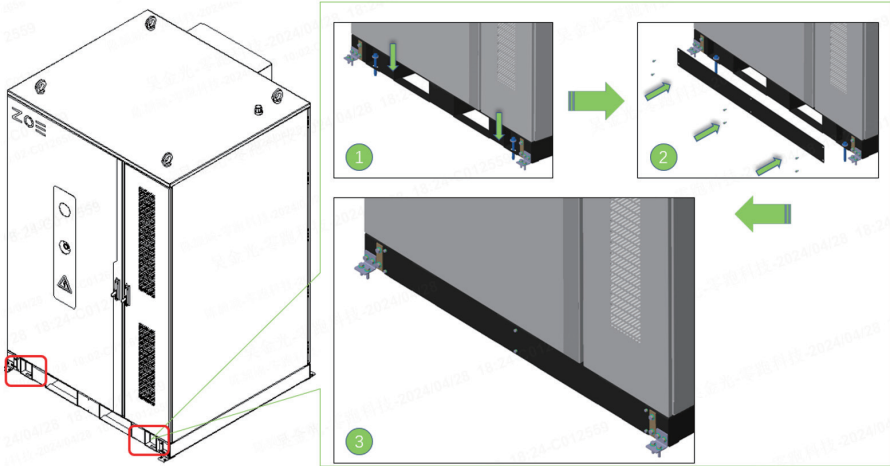

- ① The four fixing holes of the cabinet base adopt M12 bolts/nuts for fixing, with a tightening torque of $75\sim 100\text{N}\cdot\text{m}$;
- ② After fixing the base, use six M6 bolts to fix the base baffle, with a tightening torque of $8\pm 2\text{N}\cdot\text{m}$;
- ③ Completion illustration;

⚠ Caution

- If using a forklift, attention should be paid to adding protection on the forklift wall to avoid contaminating from the forklift wall or scratching the bottom of cabinet.
- Each foot of the battery cabinet is fixed with M12 bolts, and the tightening torque is set to $75\sim 100\text{N}\cdot\text{m}$.

(5) Electrical Connection

Open the cabinet door — get AC cables into the cabinet — connect grounding cables — connect AC cables — tidy the cables — seal off the inlet hole.

⚠ Caution

- The cables enter through the bottom inlet hole of the cabinet, and are led to the connection point through the trunking. It is recommended to use copper cables with the following specifications:
Model of 150KW: ZC-YJV22-0.6/1KV-95mm²
Model of 120KW: ZC-YJV22-0.6/1KV-70mm² (the wire diameter can be appropriately increased according to the on-site environment).

1. Installation Tool Preparation



Safety Gloves



Safety Glasses



Safety Shoes



Protective Clothing



Torque Screwdriver



Wire Stripper



Hydraulic Pliers



Heat Gun



Multimeter



Screwdriver



Torque Wrench

2. Open the Cabinet Door

Open the door before cable connection.

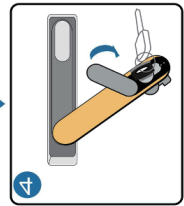
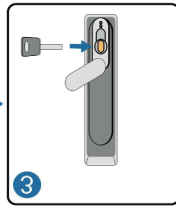
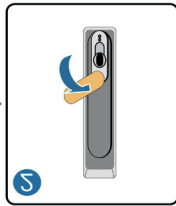
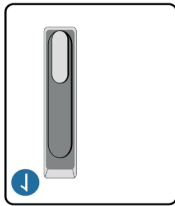

Steps	Description
1	Locked
2	Lift the cover upwards to above the locking hole
3	Insert the door key and rotate clockwise
4	Rotate the handle counterclockwise to the position shown in the figure to open the left door.

3. Cable Preparation

The selected cables must meet the following conditions:

- Have sufficient current-carrying capacity. Factors affecting the current-carrying capacity of conductors include but are not limited to:
 - Environmental conditions
 - Conductor insulation material type
 - Cable laying method
 - Cable material and cross-sectional area
- The diameter of the cable must be selected according to the maximum current-carrying capacity, and there must be a margin in length.
- All DC input cable specifications and materials should be consistent.
- The specifications and materials of three-phase AC output cables should be consistent.

- Be sure to choose flame-retardant cables.

Crimp OT/DT Terminals

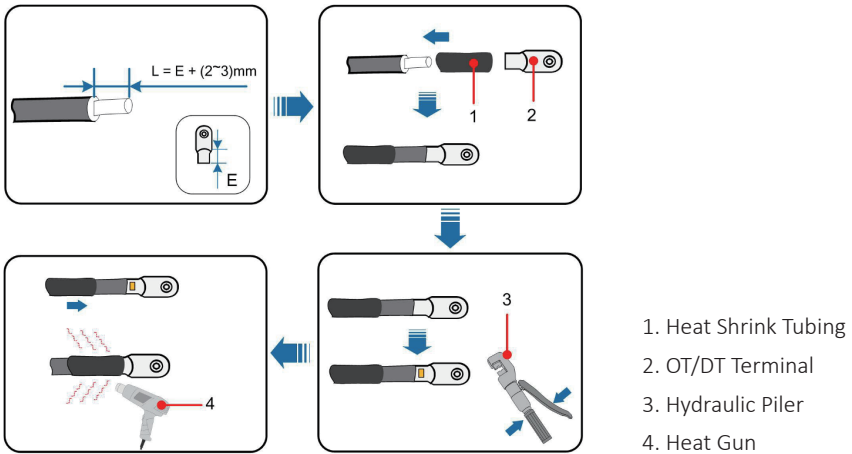

4. Copper Wire Connection

If copper cables are selected, the connection sequence of wiring components is as shown in the diagram below.

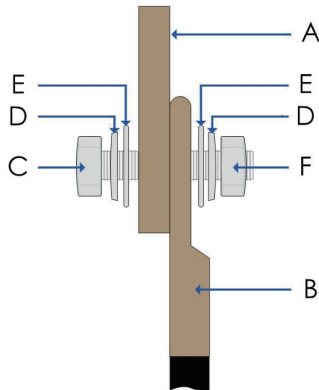

Number	Name	Number	Name
A	Copper Bar	D	Spring Washer
B	Copper Terminal	E	Flat Washer
C	Bolt	F	Nut

⚠ Caution

- Bolt tightening should be firm and reliable, with at least 2 exposed threads.

5. Ground Connection

Caution

- Grounding methods must comply with the standards and regulations of the installation location.

Grounding methods are divided into two types: using welded fixed grounding flat steel or using grounding cables.

Refer to the "2.3.1 Cabinet Appearance" for the grounding point location.

Grounding Flat Steel (recommended):

Remove the protective tape from the grounding point (if any) and weld the hot-dip galvanized flat steel to the grounding point (the overlap area between the flat steel and the cabinet is 30 mm x 100 mm). After completion, the entire fixing surface needs to be sprayed.

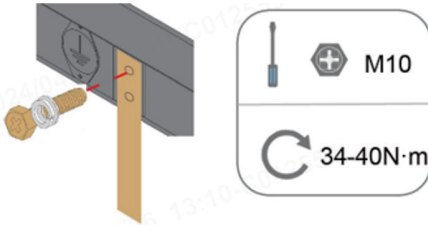

*The figures are for reference, please refer to actual product.

Please install the external grounding according to the actual situation of the project site and follow the instructions of the power station personnel. After the grounding connection is completed, the grounding resistance must be measured, and the resistance value must not exceed 4Ω .

Note

- The specific grounding resistance value must follow the relevant national/local standards and regulations.

6. Communication Wiring

Inside the BESS cabinet, there are communication interfaces for external PCS dispatch (connection port 1) and EMS communication (connection port 2).

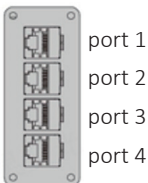

Port Name	Description
Port 1	PCS host communication port, connected to the dispatch network switch
Port 2	EMS communication port, connected to the data network switch
Port 3	Reserved
Port 4	Reserved

7. Operation After Cable Connection

After all electrical connections are completed, a comprehensive and careful check of the wiring should be performed. Also, the following operations are required:

- Ensure that all air inlet and outlet vents are free from obstruction or blockage.
- Seal tightly around the outdoor cabinet's inlet and outlet holes and surrounding gaps using fireproof and waterproof materials.

Warning

- Failure to seal correctly may result in moisture entering the equipment.
- Failure to seal correctly may allow rodent-like animals to enter.

Secure Cabinet and Box Doors

Step 1 Reinstall the protective cover for the wiring area in the reverse order of the removal method (refer to "Opening Cabinet Doors").

Step 2 Lock the cabinet doors and remove the key.

-- Complete

Caution

- After closing the cabinet doors, confirm that the sealing strips around the doors are not curled!

4 Power On and Off

Caution

- To ensure the long-term safe and reliable operation of your energy storage system, please carefully read and comply with the following instructions.
- ZOE will not be responsible for battery damage and other losses caused by failure to comply with the prescribed requirements or excessive use beyond the specified range.
- It is not recommended to power on the system at temperatures below -30°C. If the temperature is too low, the battery cell heating time will last for 24 hours or more, during which the system cannot operate normally.

4.1 Pre-power-on Check

Before powering on, carefully check the following items to ensure correctness.

- Check if the wiring is correct.
- Ensure that the protective cover inside the equipment is securely installed.

- The emergency stop button is in the released state.
- Check to ensure that there are no ground faults.
- Use a multimeter to check if the AC and DC side voltages meet the starting conditions and if there is no overvoltage danger.
- Check to ensure that no tools or parts are left inside the equipment.
- Ensure that all air inlet and outlet vents are free from obstruction or blockage.

4.2 Power-on Steps

Before powering on, a comprehensive and detailed inspection of the equipment must be carried out to ensure that all indicators meet the requirements before power-on.

- Power and communication wiring for the cabinet have been completed.
- Step 1 Confirm that the emergency stop on the cabinet is in the reset state.
- Step 2 Close the QF (main AC switch) on the panel, and the AC side of the system is powered on.
- Step 3 Close QF1-6 (AC auxiliary switch) on the panel, and the auxiliary power supply is powered on.
- Step 4 Press the UPS-ON button (UPS switch) on the uninterruptible power supply, the auxiliary distribution of the system is powered up, press the auxiliary power button on the high-voltage box, and the indicator lights up (EMS, fire protection, high-voltage box, and other equipment are powered on).
- Step 5 Rotate the DC switch handle of the high-voltage box to "ON".
- Step 6 Operate the software to boot up the system.

4.3 Power Off and Shutdown

4.3.1 Planned Shutdown

Planned shutdown status is the state where the facility is planned to be shut down for maintenance, testing, and repair. Operate the software to shut down system, and the battery relay is disconnected (in special cases, shutdown can be performed by pressing the emergency stop button on the cabinet).

Step 1 Power-off preparation: Operate the software to shut down system (in special cases, shutdown can be performed by pressing the emergency stop button on the cabinet).

Step 2 Disconnect the QF (main AC switch) on the Panel.

Step 3 Disconnect the QF1-6 (AC auxiliary switch) on the panel.

Step 5 Rotate the DC switch handle of the high-voltage box to "OFF".

Step 5 Turn off the uninterruptible power supply, press to reset the power button on the

high-voltage box, and the indicator light goes off.

⚠ Danger

Before operating the AC terminal, be sure to disconnect the upstream switch of the BESS.

-- Complete. Wait for the system to discharge before rechecking the electricity.

4.3.2 Non-scheduled (emergency) shutdown

In case of emergency, contact local fire department professionals.

5 Equipment Operation Control

The energy storage operation and maintenance platform provides functions such as asset probability, micro-grid monitoring, intelligent monitoring, alarm management, battery analysis, operation center, strategy control, micro-grid reporting, resource management, user center, IOT center, and developer center, realizing one-stop energy storage operation and maintenance management.

5.1 Login

The user enters the login page, enters the tenant code, account, password, and verification code, and clicks the login button to log in. After logging in, you can click on the upper right corner to view your personal information or log out.

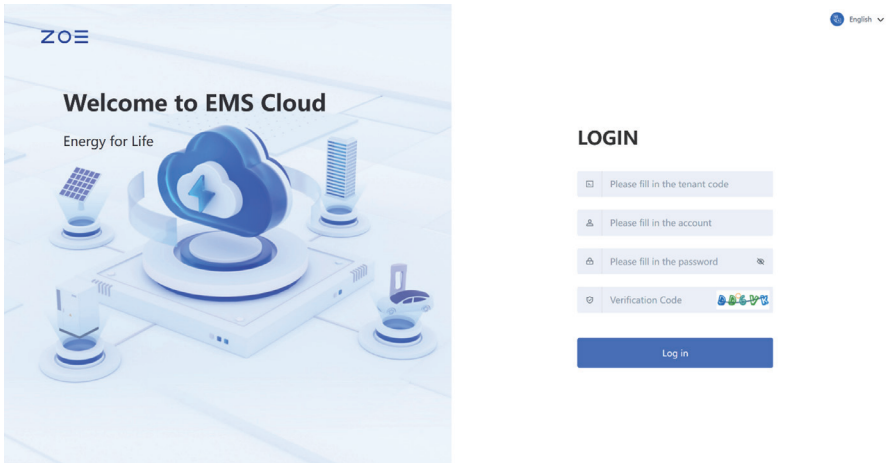

5.2 System Overview Interface

After successfully logging in, the asset overview page shows the zone quantity statistics, maps, revenue analysis, operating indicators and social contributions.

The statistics of the number of zones show the number of zones and the number of energy storage stations, photovoltaic stations and charging pile stations under the zone, as well as the parameters of the stations.

The map module shows the revenue ranking of the zone and the distribution of stations. The map of China is displayed by default. The number of stations is displayed in the picture. Click the number icon to enlarge the map to display the location of the station. After clicking on the location, the station information is displayed. Click on the zone to jump to the corresponding zone monitoring interface.

Revenue analysis counts revenue from the site level and the time level, respectively. Energy storage, photovoltaic, charging piles and cumulative revenue are counted at the site level; the time level counts the income of this month, the previous month and the current year respectively. At the same time, the income statistics for the past six months show the income trend.

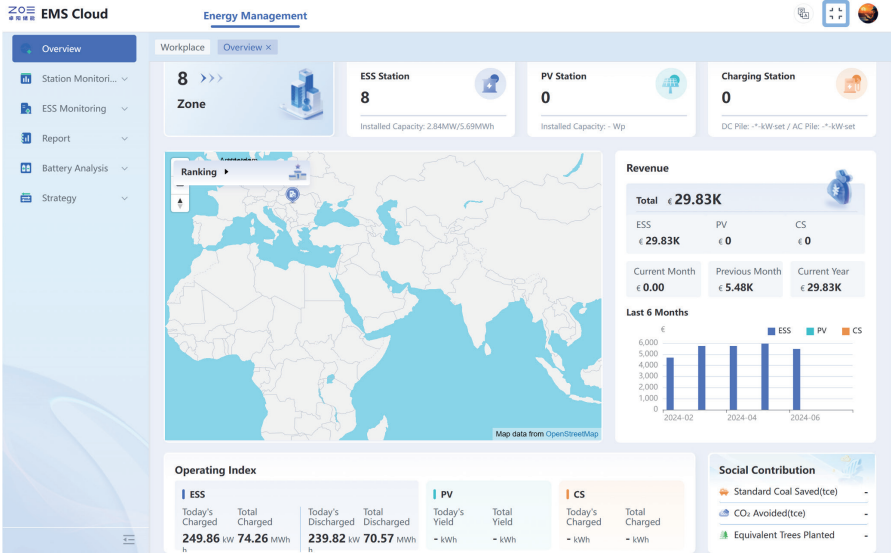

6 Warranty Description

The warranty of all equipment shall be subject to the contract requirements and technical and commercial agreements between the two parties.

During the warranty period, the supplier shall arrange professional personnel to conduct necessary testing and maintenance of the equipment in accordance with the contract requirements.

7 Note

(1) In order to protect the legitimate rights and interests of both parties and avoid unnecessary losses, the following reasons for product failure or damage will not be eligible for free service:

- Your equipment exceeds the warranty period;
- Equipment damage caused by incorrect installation and use not in accordance with the instructions;
- Your equipment has been repaired by unauthorized personnel;
- Your equipment uses non-standard or publicly unreleased software or other non-standard expansion components not certified by our company, as well as other damage caused by force majeure such as natural disasters.

In order to safeguard your rights and interests, ZOE will provide high-quality after-sales service. We welcome your supervision of our work and valuable opinions.

The above commitments are only for this product!

(2) Maintenance and system precautions: To ensure the continuous normal operation of the system, it is required to regularly maintain the system:

- Regularly check whether the cables are aging, whether the cable connection points are fastened and safe;
- Before opening the cabinet for maintenance, the secondary loop power supply should be completely disconnected, and the circuit breakers of the grid-connected cabinet, isolation switches, and isolation switches of each high-voltage box should be disconnected. The system should be stopped for 5 minutes or longer before maintenance. During disassembly and maintenance, pay attention not to damage the system components and electrical components;
- After system maintenance, a trial run should be conducted before re-operation to ensure reliable operation of the system after maintenance;
- When the product fails to work due to a fault, preliminary problem location and handling can be carried out according to the appendix instructions;
- If the problem cannot be solved, please contact our engineering personnel as soon as possible, and do not disassemble parts for illegal maintenance.

8 Appendix

8.1 Common Fault Information and Partial Handling Measures

Fault	Possible Causes	Handling Measures	Remarks
System cannot start normally	<ol style="list-style-type: none"> 1. Secondary circuit of the system is not powered 2. Some switches are not closed 3. Other reasons 	<ol style="list-style-type: none"> 1. Check if the monitoring power indicator light is on 2. Refer to the electrical diagram to see if some switches are not closed 3. If still doesn't work, please contact the manufacturer for after-sales service 	After troubleshooting, the system can be restarted
System/single cell over-voltage shutdown protection	<ol style="list-style-type: none"> 1. System/single cell overvoltage 2. Battery sampling cables disconnected or sampling cables plug connection unreliable. 3. BMU abnormal 	Re-plug the power plug of the battery sampling, check the system battery voltage, replace battery cells if battery cells abnormal.	After troubleshooting, refer to the "Human-Machine Interface Manual" for manual startup operations. After completion, the system can be restarted.
System/Single Cell Under-voltage Shutdown Protection	<ol style="list-style-type: none"> 1. System/single cell undervoltage 2. Battery sampling cables short-circuited or sampling cables plug connection unreliable. 3. BMU abnormal 4. Other reasons 	Re-plug the power plug of the battery sampling, check the system battery voltage, replace battery cells if battery cells abnormal.	
Charging/Discharging over-temperature shutdown protection	<ol style="list-style-type: none"> 1. System battery temperature is higher than the high-protected value. 2. Temperature sampling cables disconnected or sampling cables plug unreliable. 3. BMU abnormal 4. Other reasons 	Re-plug the power plug of the battery sampling, check if the air conditioning is operating normally, and if not, please contact the manufacturer's after-sales service.	
Charging/Discharging under-temperature shutdown protection	<ol style="list-style-type: none"> 1. System battery temperature is lower than the low-protected value. 2. Temperature sampling cables disconnected or sampling cables plug unreliable. 3. BMU abnormal 4. Other reasons 	Re-plug the power plug of the battery sampling, check if the air conditioning is operating normally, and if not, please contact the manufacturer's after-sales service.	
Charging/Discharging over-current shutdown protection	Charing/Discharging current is higher than the protected current	Check if the PCS is operating normally, if not, please contact the manufacturer's after-sales service.	
System insulation failure	<ol style="list-style-type: none"> 1. System insulation detection failure 2. Electric leakage 	Apply remote backend to shut down PCS, disconnect DC switches, and contact the manufacturer's after-sales service.	
BCU and BMU Communication Failure	<ol style="list-style-type: none"> 1. BMS not powered 2. Corresponding communication cable loose 	Check if the BMS system is powered properly, inspect if the corresponding BCU and BMU communication plug is loose, and if the cable is damaged.	After troubleshooting, the system can be restarted.
BMS and PCS Communication Failure	<ol style="list-style-type: none"> 1. BMS not powered 2. PCS not powered 3. Corresponding communication cable loose 	Check if the whole BESS is powered properly, inspect if the corresponding BMS and PCS communication plug is loose, and if the cable is damaged.	After troubleshooting, the system can be restarted.
Air conditioning and BMS Communication Failure	<ol style="list-style-type: none"> 1. BESS not powered 2. Corresponding communication cable loose 	Check if the whole BESS is powered properly, inspect if the corresponding communication plug is loose, and if the cable is damaged.	After troubleshooting, the system can be restarted.
SOC value abnormal	<ol style="list-style-type: none"> 1. SOC value not calibrated 2. SOC accumulation error 	Perform a complete charging and discharging cycle	

For other fault details, please refer to the Z BOX-I O&M Manual V1.0.

8.2 Contact Information

If you have any questions about this product, please contact us!

To provide you with faster and better after-sales service, we need your assistance in providing the following information:

- Device model _____
 - Device Serial Number _____
 - Fault code/name _____
 - Brief Description of Fault _____
- _____
- _____
- _____

Version Number: 1.0-202404

While the product is being improved, the manual may be changed without prior notice.



VISIT
WEBPAGE



FOLLOW
US

Fuzhou ZOE Energy Storage Technology Co., Ltd.

Factory ADD: Zone 1, Intelligent Manufacturing Industrial Park, Nanfeng, Fuzhou, Jiangxi, P.R. China

Technical support email: info@zoeess.com

Company website: <https://www.zoeess.com/>

Energy for Life